

Dynamic Frequency Selection (DFS) and the 5GHz Unlicensed Band

by Mark Briggs, Principal Engineer at Elliott Labs

The advent of the 802.11a wireless market and the constant push to open up new spectrum for unlicensed use created a requirement for Dynamic Frequency Selection (DFS), a mechanism to allow unlicensed devices to share spectrum with existing radar systems. The regulatory requirements for DFS, along with requirements for Transmit Power Control (TPC) and uniform channel loading have been adopted in the US, Europe and Japan and are being considered by many other regulatory domains looking at adopting the 5GHz bands for unlicensed, and possibly licensed devices. In the next few chapters, I hope to provide an overview of the current and proposed DFS requirements for Europe and the proposed DFS requirements for the US.

European Union

ETSI standard EN 301 893 V1.2.3 [1], the European Union's harmonized radio standard for unlicensed devices operating in the 5150 – 5350 MHz and 5470 – 5725 MHz frequency bands, was one of the first standards to reference DFS. It specifies the types of waveforms that systems operating in the 5250 – 5350 MHz and 5470 – 5725 MHz bands should detect and defines threshold and timing requirements as follows:

Channel Availability Check Time: The time a system shall monitor a channel for presence of radar prior to initiating a communications link on that channel.

Interference Detection Threshold: The minimum signal level, assuming a 0dBi antenna, that can be detected by the system to trigger the move to another channel.

Channel Move Time: The time for the system to clear the channel and measured from the end of the radar burst to the end of the final transmission on the channel.

Channel Closing Transmission Time: The total, or aggregate, transmission time from the system during the channel move time.

Non-Occupancy Time: A period of time after radar is detected on a channel that the channel may not be used.

Master Device: Device that has radar detection capabilities and can control other devices in the network (e.g. an Access Point would be considered a master device)

Slave Device: Device that does not initiate communications on a channel without authorization from a master device (e.g. a laptop WiFi card – note that a WiFi card that supports ad-hoc mode would be considered a master device)

The operation of a system with DFS capability takes the following sequence (refer also to Figure 1):

1. The master device that can initiate communication selects a channel and monitors that channel for potential radar interference for a minimum listening time (channel availability check time). No transmissions can occur during this period.
2. If interference is detected then the system has to go and select another channel and repeat the channel availability check on the new channel (the original channel is added to a list of channels with radar).
3. Once a channel has been selected and passes the channel availability check interference the network starts to use that channel.
4. While using the channel the network's master device continuously monitors for potential interference from a radar source (this is referred to as in-service monitoring). If interference is detected then the network master device issues commands to all other in-network devices to cease transmissions. The channel is added to the list of channels with radar.
5. The master device then selects a new channel (one that is not on the radar list).
6. A channel on the radar list can be purged once the non-occupancy period has elapsed for that channel.

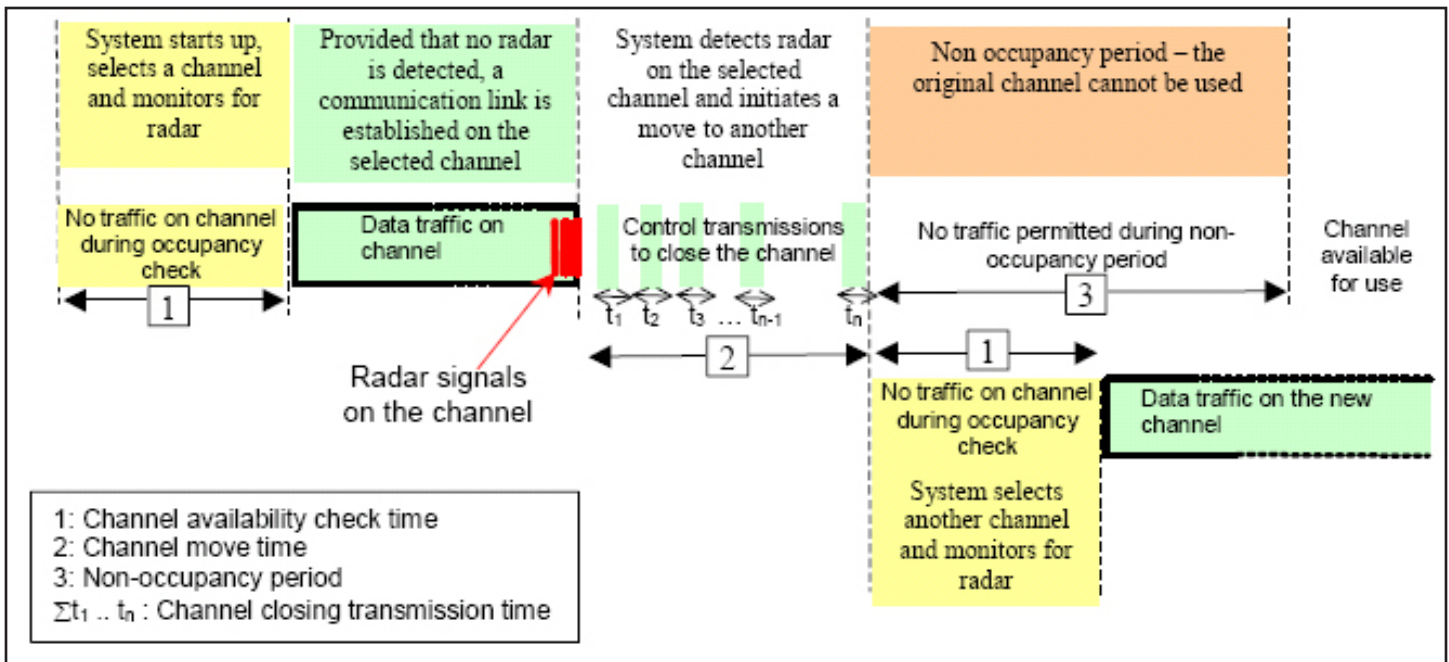

Figure 1: DFS Timing Requirements

While master devices are required to employ interference detection capabilities, EN 301 893 does not require this feature for slave devices provided that they:

1. Operate below a power level of 200mW;
2. Are not capable of initiating communication on a channel (in effect, this prohibits them from using active scanning to detect a wireless network);
3. May only operate on a channel under control of a device with the detection capability (a master device).

Slave devices must respond to the commands to move to another channel from the master device when it (the master device) detects radar, and both slave and master devices must meet the channel move time and channel closing transmission time.

To demonstrate the DFS capability a system (master/slave pair) is evaluated for its ability to detect 3 specific pulse patterns in the presence of data traffic between the two (10% traffic is the requirement of EN 301 893 V1.2.3). The pulse patterns have three critical parameters – pulse repetition frequency (PRF), pulse width and burst length – and these are shown in Table 1. One of these radar types is also used to verify the channel availability check time.

The system (master/slave combination) is considered to have met the DFS requirements if the timing and threshold parameters comply with the values listed in Table 2.

The standard details the test methods to be employed to evaluate the radar detection capabilities of a master/slave pair. It permits the use of both radiated and direct connection methods of coupling the radar signals into the detection device.

The V1.2.3 version of EN 301 893 fails to address the success rate for detection of the radar bursts - if a system fails to detect a radar burst the first time the test is performed, but is successful on the second test, is that a pass or a fail? The latest version of EN 301 893 V1.3.1 [2] addresses this by specifying a detection success rate for each radar type and a minimum number of times to repeat the test (20). In addition the radar parameters have been altered to include some parameters to be selected at random from a list and the amount of traffic on the channel during the in-service monitoring test is increased from 10% to 30%. Table 3 summarizes the new waveform parameters.

Signal	PRF	Pulse Width	Burst Length
Radar Signal #1	700 Hz	1µs	26ms (18 pulses)
Radar Signal #2	1800 Hz	1µs	5ms (10 pulses)
Radar Signal #3	330 Hz	2µs	210ms (70 pulses)

Table 1: EN 300 328 V1.2.3 Radar Parameters

Parameter	Requirement
Channel availability check time	60s (minimum)
Channel Move time	10s (maximum)
Channel Closing Time	260ms (maximum)
Interference Detection Threshold (Master Device)	-64dBm Transmit power \geq 200mW
	-62dBm Transmit power $<$ 200mW
Interference Detection Threshold (Slave Device)	-64dBm Transmit power \geq 200mW
	Not required if transmit power $<$ 200mW
Non-occupancy period	30 minutes (minimum)

Table 2: EN 301 893 V1.2.3 DFS Requirements

	Pulse Width (µs)	Pulse repetition interval (µs)	Pulses per burst	Pulse	Detection Success Rate
Type 1	1	750	15	None	$>$ 60%
Type 2	1, 2 or 5	200, 300, 500, 800 or 1000	10	None	$>$ 60%
Type 3	10 or 15	200, 300, 500, 800 or 1000	15	None	$>$ 60%
Type 4	1, 2, 5, 10 or 15	1200, 1500 or 1600	15	None	$>$ 60%
Type 5	1, 2, 5, 10 or 15	2300, 3000, 3500 or 4000	25	None	$>$ 60%
Type 6	20, 30	2000, 3000 or 4000	20	5 MHz (\pm 2.5MHz) chirp	$>$ 60%

Table 3: EN 301 893 V1.3.1 Waveform Parameters

Although formal testing would only be performed using one radar of each type, manufacturers need to know that their systems can detect all possible combinations of pulse width, pulse repetition frequency and burst lengths.

USA

The FCC had already opened up the 5150 – 5350 MHz band when it adopted the UNII rules into Part 15. The FCC opened up the 5470 – 5725 MHz band by working with industry and the Department of Defense through the U.S. Department of Commerce, National Telecommunications and Information Administration (NTIA) and released its Report and Order FCC

03-287 [3]. To release the 5470 – 5725 MHz a requirement for DFS was proposed to cover the new band and the existing 5250 – 5350 MHz band. The timing and threshold requirements were identical to those of EN 301 893 v1.2.3, but the signal parameters were different and included a frequency hopping radar (Table 4).

The original time line for these bands would have required any devices using the 5250 – 5350 MHz band that would be certified after January 2005 to have the DFS capability. Issues with the implementation of a test procedure (such as detection success rates) and the radar parameters caused the postponement of this date to January 2006. The main concern from the

Signal	PRF	Pulse Width	Burst Length	Hopping Rate
Radar Signal #1	700 Hz	1µs	26ms (18 pulses)	n/a
Radar Signal #2	1800 Hz	1µs	5ms (10 pulses)	n/a
Radar Signal #3	3000 Hz	1µs	100ms (300 pulses)	1kHz

Table 4: FCC-03-287 Proposed Radar Parameters

	Pulse Width (µs)	Pulse repetition interval (µs)	Pulses per burst	Pulse Modulation	Hopping Rate
Bin 1	1	1428	18	None	n/a
Bin 2	1-5	150-230	23-29	None	n/a
Bin 3	5-10	250-500	16-18	None	n/a
Bin 4	10-20	250-500	12-16	None	n/a
Bin 5	50-100	1000-5000	1-3	5-20 MHz linear chirp	n/a
Frequency Hopping	1	333	9 pulses per hop, 100 hops per burst		333 Hz

The bin 5 waveform is to be made of between 8 and 20 bursts over a 12 second period. Each burst contains one, two or three pulses. Each pulse within a burst has the same modulation and width but the repetition interval (for the three-pulse burst) can be different between the first and second, and second and third pulses). The parameters for the pulses in different bursts are not identical.

Table 5: Latest Proposed FCC Radar Waveforms

government’s side was that the detection algorithms implemented might only look for signals with the specific parameters listed and industry was concerned that detection rates might not be achievable in the proposed, high-traffic (50% channel utilization) environment.

At the time of writing (October 2005) the detection success rates, radar parameters and test methods were being resolved. Some consensus had been made to the radar parameters, and the latest are detailed in Table 5. As can be seen, the radar parameters include a range of values with the intent that, at the time a formal test is performed, each parameter would be selected at random from the range of possible values.

The big challenge for the FCC-related test methods was to develop methods for evaluating the frequency hopping radar (preferably avoiding test labs having to invest in expensive frequency agile signal generators) and the ability to generate the bin 5, long duration waveform that includes chirped pulses of varying

lengths. Recent trials by NTIA have demonstrated that devices are capable of detecting the various waveforms and also validated some alternate test procedures for simulating frequency hopping waveforms.

Additional trials with real radars will be the next step, and these results and further discussions between industry and government will hopefully finalize the test procedures and pass/fail criteria. Once these issues have been resolved any products that require certification and need to demonstrate a DFS capability will have to be certified by the FCC and it is very likely that the FCC will also want to do surveillance audits on many devices until DFS capabilities have been proven.

As the 5GHz bands are opened up in other geographic areas it can be expected that DFS requirements will be included in each country’s spectrum allocation. Once the US has ironed out the prevailing issues with its DFS requirements it is hoped that the concordance reached between the various industry and

governmental parties will assist in making regulations that match the requirements of existing spectrum users and new wireless technologies.

1. *EN 301 893 V1.2.3, "Broadband Radio Access Networks (BRAN); 5 GHz high performance RLAN; Harmonized EN covering essential requirements of article 3.2 of the R&TTE Directive" published by ETSI*
2. *ETSI EN 301 893 V1.3.1 (2005-08), Candidate Harmonized European Standard (Telecommunications series) Broadband Radio Access Networks (BRAN); 5 GHz high performance RLAN; Harmonized EN covering essential requirements of article 3.2 of the R&TTE Directive*
3. *Federal Communications Commission Report and Order FCC 03 287 released November 18, 2003*



Mark Briggs is a Principal Engineer with Elliott Labs (www.elliottlabs.com, info@elliottlabs.com), a test lab and TCB in the San Francisco Bay Area. Mark has been involved in EMC and Radio testing for the last 11 years.

About Elliott Laboratories Inc.

Based in the heart of Silicon Valley, Elliott Laboratories is a world-class Regulatory Compliance Laboratory. With over 25 years of experience servicing the needs of product manufacturers, Elliott's clients save time and money by achieving their regulatory compliance requirements quickly and efficiently, enabling them to bring their products to market without costly delays. Elliott continues to pursue a course of partnering with best-in-class service providers to offer a full-service compliance solution designed to meet the needs of even the most demanding product manufacturers. For more information, visit www.elliottlabs.com.